

01-72 SERIES

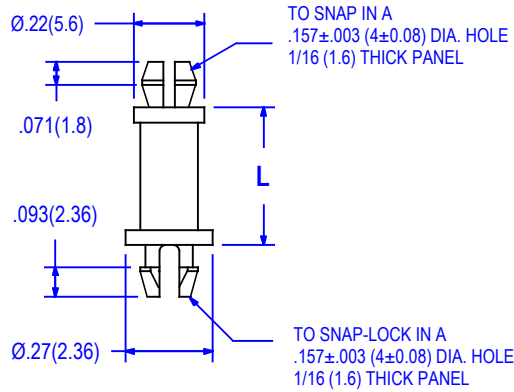

ITEM NO.	L	
	In. ±.015	mm. ± 0.4
01-72-30	.187	4.8
01-72-40	.250	6.4
01-72-50	.312	7.9
01-72-60	.375	9.5
01-72-70	.437	11.1
01-72-80	.500	12.7
01-72-100	.625	15.9
01-72-110	.687	17.5
01-72-120	.750	19.1
01-72-140	.875	22.2

PACKAGING : 1000 PER BAG

MATERIAL	NYLON 66
UL RATING	94V-2
UL FILE NO.	E41938
COLOR	NATURAL
ASTM	D 4066, PA111
RoHS COMPLIANCE	YES
TEMPERATURE RANGE (REF.)	-40 to 185°F (-40 to 85°C)
MR NUMBER	12

UL 94V-O MATERIAL AVAILABLE UPON REQUEST
TO ORDER ADD SUFFIX "X" TO ITEM NUMBER

						BY	DATE	Title PC BOARD SUPPORT 01-72 SERIES.
						CUSTOMER APPROVAL		
						VERIFIED		
						REVIEWED	FL	Part No. SEE TABLE
						DRAWN	FL 09-04-14	
						DIMENSIONS Inches (mm) Tolerance .xx = ± .010 .xxx = .005		Issue O 09-04-14
					ALL ELECTRONICS HARDWARE INC. 2642 Corporate Parkway Algonquin, IL. 60102 1-800-778-7234		Drwg. type CATALOG	
No	Revision	Date	Init.			File No. 01-72 series		